

Wire Diagram

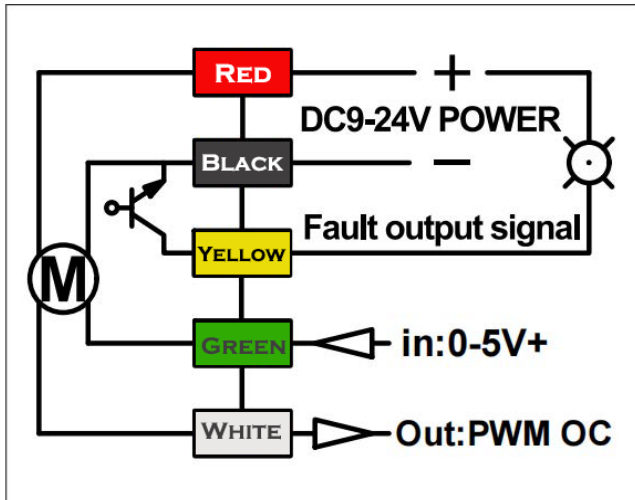

MOD01

- 1、RD(red wire) connects to DC9-24V positive pole;
- 2、BK(black wire) connects to DC9 ~ 24V negative pole, and it is also 4-20mA-/0-5V-/0-10V's negative pole;
- 3、GR(green wire) connects to analogy signal positive pole (e.g. 4-20mA, 0-5V, 0-10V) ;
- 4、YW(yellow wire) connects to ERROR output negative pole. Wet contact NPN triode collector output. When there is an error causing the motor to work with excessive current, such as when debris blocks the valve and the ball cannot rotate, the contact is closed; when working normally, the contact open, it only can pull down the external signal. The load is 500mA
- 5、WT(white wire) connects to position feedback negative pole. Wet contact NPN triode collector output, OC output PWM signal, 100Hz, 5%-95%, indicating 0-90 degrees. The load is 500mA.

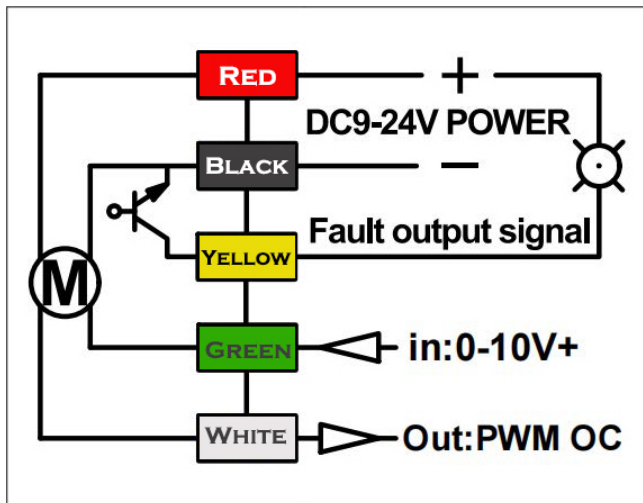

MOD02

- 1、RD(red wire) connects to DC9-24V positive pole;
- 2、BK(black wire) connects to DC9 ~ 24V negative pole, and it is also 4-20mA-/0-5V-/0-10V's negative pole;
- 3、GR(green wire) connects to analogy signal positive pole(e.g. 4-20mA, 0-5V, 0-10V) ;
- 4、YW(yellow wire) connects to ERROR output negative pole. Wet contact NPN triode collector output. When there is an error causing the motor to work with excessive current, such as when debris blocks the valve and the ball cannot rotate, the contact is closed; when working normally, the contact open, it only can pull down the external signal. The load is 500mA
- 5、WT(white wire) connects to position feedback negative pole. Wet contact NPN triode collector output, OC output PWM signal, 100Hz, 5%-95%, indicating 0-90 degrees. The load is 500mA.

Wire Diagram

MOD03

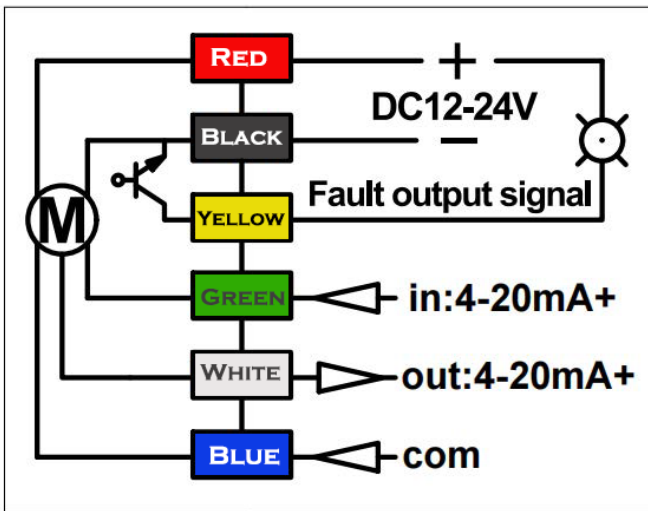

- 1、 RD(red wire) connects to DC9-24V positive pole;
- 2、 BK(black wire) connects to DC9 ~ 24V negative pole, and it is also 4-20mA-/0-5V-/0-10V's negative pole;
- 3、 GR(green wire) connects to analogy signal positive pole(e.g. 4-20mA, 0-5V, 0-10V) ;
- 4、 YW(yellow wire) connects to ERROR output negative pole. Wet contact NPN triode collector output. When there is an error causing the motor to work with excessive current, such as when debris blocks the valve and the ball cannot rotate, the contact is closed; when working normally, the contact open, it only can pull down the external signal. The load is 500mA
- 5、 WT(white wire) connects to position feedback negative pole. Wet contact NPN triode collector output, OC output PWM signal, 100Hz, 5%-95%, indicating 0-90 degrees. The load is 500mA.

MOD04

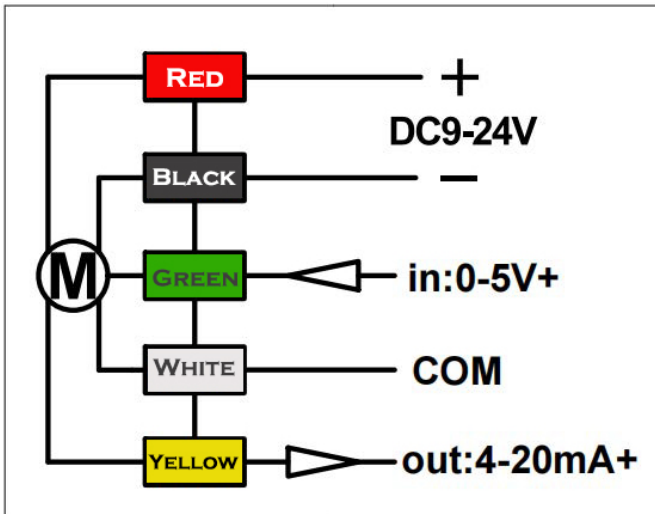

1. RD(red cable) connects DC9-24V positive pole
2. BK(black cable) connects DC9 ~ 24V-negative pole
3. GR(green cable) connects position input /control current +/ control voltage 0-5V
4. WT(white cable) connects common signal
5. YW(yellow cable) connects position feedback positive,output 4-20mA signal

*When output signal is 4-20mA, the biggest input voltage of load resistance is $(v-2)/0.02$, e.x. power is 15V, $(15-2)/0.02=650\Omega$, suggest to use 300Ω

Wire Diagram

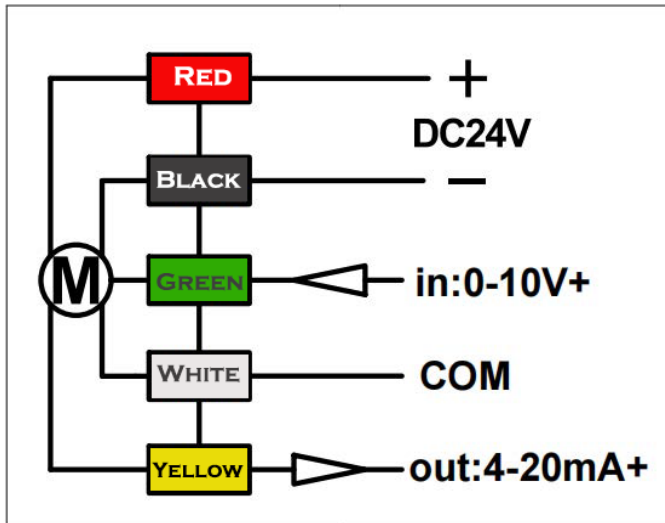

MOD06

1. RD(red cable) connects DC9-24V positive pole
2. BK(black cable) connects DC9 ~ 24V negative pole
3. GR(green cable) connects position input / control current +/- control voltage 0-10V
4. WT(white cable) connects common signal
5. YW(yellow cable) connects position feedback positive, output 4-20mA signal

*When output signal is 4-20mA, the biggest input voltage of load resistance is $(v-2)/0.02$, e.g. power is 15V, $(15-2)/0.02=650\Omega$, suggest to use 300 Ω

MOD07

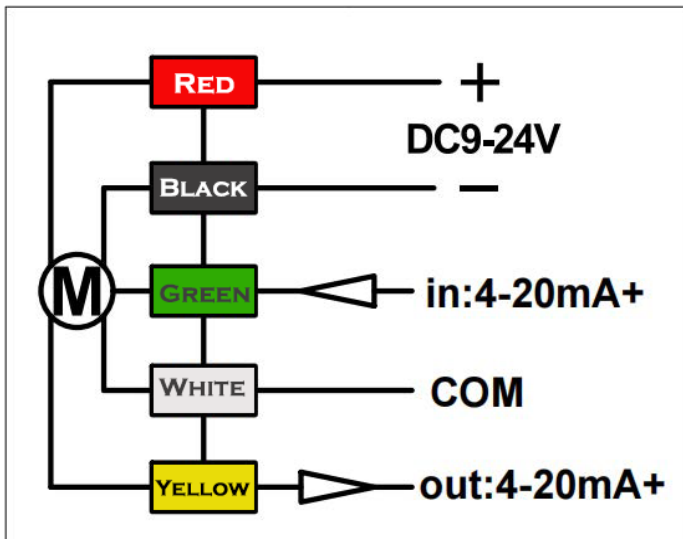

1. RD(red wire) connects to DC9-24V positive pole;
2. BK(black wire) connects to DC9-24V negative pole;
3. GR(green wire) connects to analogy(4-20mA) signal's positive pole;
4. WT(white wire) connects to negative poles of input analogy signal and output signal
5. YW(yellow wire) connects to position feedback positive pole, output signal 4-20mA is the feedback signal.

* When output signal is 4-20mA, the maximum load resistance is the input power voltage $(v-2) / 0.02$, e.g. if the power is 15V, then $(15-2)/0.02=650\Omega$, it is recommended to use a 300 Ω load resistor.

Wire Diagram

MOD08

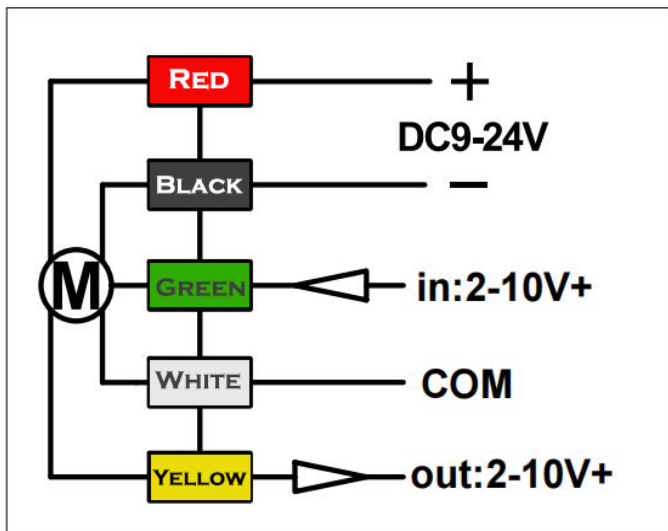

- 1、 RD(red wire) connects to DC9-24V positive pole;
- 2、 BK(black wire) connects to DC9 ~ 24V negative pole, and it is also 4-20mA-/0-5V-/0-10V's negative pole;
- 3、 GR(green wire) connects to analogy signal positive pole(e.g. 4-20mA, 0-5V, 0-10V) ;
- 4、 YW(yellow wire) connects to ERROR output negative pole. Wet contact NPN triode collector output. When there is an error causing the motor to work with excessive current, such as when debris blocks the valve and the ball cannot rotate, the contact is closed; when working normally, the contact open, it only can pull down the external signal. The load is 500mA
- 5、 WT(white wire) connects to position feedback negative pole.

Wet contact NPN triode collector output, OC output PWM signal, 100Hz, 5%-95%, indicating 0-90 degrees. The load is 500mA.